

## ARTICULO: 2025

### Válvula de esfera paso total 3 piezas Inoxidable *Stainless steel full port ball valve, 3 pieces*

Características
1. Válvula esfera paso total 3 piezas
2. Extremos roscados según ISO 7-1 (EN 10226-1).
3. Construcción en acero inox. 1.4408 (CF8M).
4. Asientos PTFE + 15 % Fibra de Vidrio. (otro material consultar)
5. Tórica en el eje de FKM (Viton).
6. Juntas del eje PTFE + 15 % Grafito.
7. Sistema de bloqueo.
8. Montaje actuador directo s/ ISO 5211.
9. Eje inexpulsable.
10. Presión de trabajo máxima 63 bar.
11. Temperatura de trabajo -25 °C + 180 °C.

Features
1. <i>Stainless steel full port ball valve, 3 pieces.</i>
2. <i>Thread ends according to ISO 7-1 (EN 10226-1).</i>
3. <i>Made of stainless steel 1.4408 (CF8M).</i>
4. <i>Ball seats PTFE + 15 % G.F.</i> (please ask for other materials)
5. <i>O'ring in the stem FKM (Viton).</i>
6. <i>Stem gasket PTFE + 15 % Graphite.</i>
7. <i>Locking system.</i>
8. <i>Direct mounting actuator ISO 5211.</i>
9. <i>Blow-out proof stem.</i>
10. <i>Max. working pressure 63 bar.</i>
11. <i>Working Temperature -25 °C + 180 °C.</i>

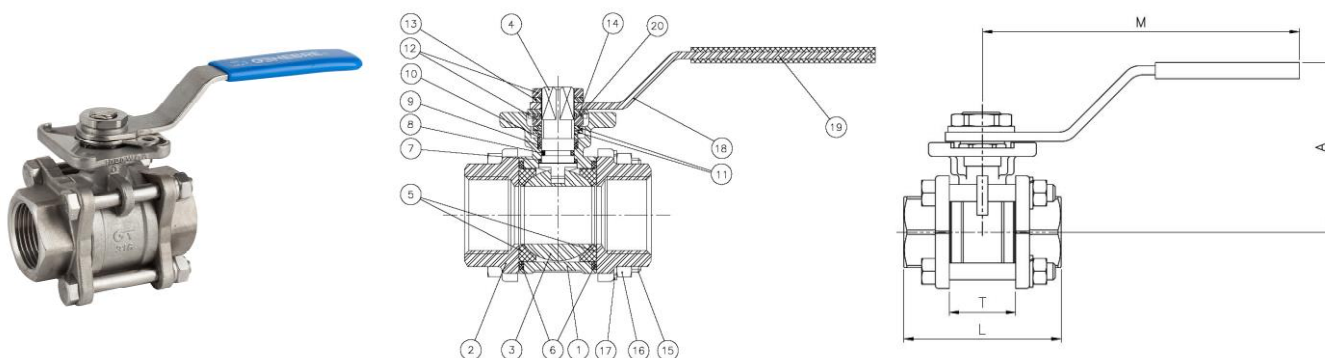

Nº	Denominación / Name	Material	Acabado Superficial / Surface Treatment	Cód. Recambio Spare Part Code
1	Cuerpo / Body	Acero Inox. / Stainless Steel 1.4408	Granallado / Shot blasting	-----
2	Tapa / Cap	Acero Inox. / Stainless Steel 1.4408	Granallado / Shot blasting	-----
3*	Bola / Ball	Acero Inox. / Stainless Steel 1.4408	Pulido / Polishing	2907 / 2904 (4")
4*	Eje / Stem	Acero Inox. / Stainless Steel AISI 316	-----	2905
5*	Asiento / Ball Seat	PTFE + 15% F.V. / G.F.	-----	2820
6*	Junta / Gasket	PTFE + grafito / graphite	-----	2820
7*	Arandela / Thrust Washer	PTFE + grafito / graphite	-----	2820
8*	Tórica / O'ring	FKM	-----	2820
9*	Empaquetadura / Stem packing	PTFE	-----	2820
10	Anillo Prensa / Gland	Acero Inox. / Stainless Steel AISI 304	-----	-----
11	Arandela Belleville / Belleville Washer	Acero Inox. / Stainless Steel AISI 301	-----	-----
12	Tuerca / Nut	Acero Inox. / Stainless Steel AISI 304	-----	-----

13	Arandela / Washer	Acero Inox. / Stainless Steel AISI 304	-----	-----
14	Tope / Stopper	Acero Inox. / Stainless Steel AISI 304	-----	-----
15	Tornillo / Bolt	Acero Inox. / Stainless Steel AISI 304	-----	-----
16	Tuerca / Nut	Acero Inox. / Stainless Steel AISI 304	-----	-----
<b>Nº</b>	<b>Denominación / Name</b>	<b>Material</b>	<b>Acabado Superficial / Surface Treatment</b>	<b>Cód. Recambio Spare Part Code</b>
17	Arandela Grover / Grover washer	Acero Inox. / Stainless Steel AISI 304	-----	-----
18	Maneta / Handle	Acero Inox. / Stainless Steel AISI 304	-----	-----
19	Funda / Handle Sleeve	Vinilo / Vynil	-----	-----
20	Antigiro / Lock Washer	Acero Inox. / Stainless Steel AISI 304	-----	-----

\* Piezas de recambio disponibles / Available spare parts

Únicamente en medidas de 2 ½" a 4" / For 2 ½" – 4" Sizes Only

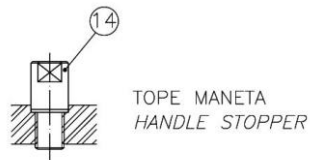

Detalle de la zona de Eje / Stem detail

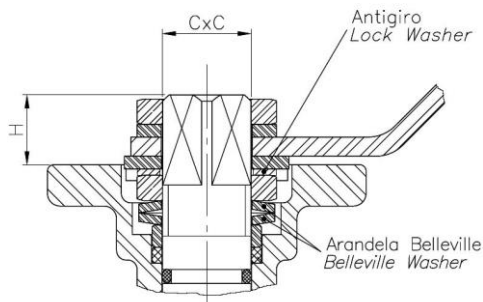

Antigiro / Lock Washer: Previene el desajuste de la tuerca del

eje en elevados ciclos de maniobra / Prevents unthreading of stem nut in high cycle automation applications.

Arandela Belleville / Belleville Washer: Las arandelas belleville proporcionan una carga constante sobre el prensa asegurando un cierre firme en variaciones de condiciones de trabajo. / Standard belleville washers provide constant "live load" on the stem seals, assuring a tight seal even varying service parameters.

**DIMENSIONES GENERALES / GENERAL DIMENSIONS**

Ref	Medida / Size	PN	Paso / Port	Dimensiones / <i>Dimensions</i> (mm)				Peso / Weight (Kg)
				A	L	M	T	
2025 02	1/4"	63	11	60	47.6	112	23	0.390
2025 03	3/8"	63	12.7	60	47.6	112	23	0.380
2025 04	1/2"	63	15	60	56	112	24	0.440
2025 05	3/4"	63	20	70	73	138	30	0.820
2025 06	1"	63	25	70	82	138	33.5	1.020
2025 07	1 ¼"	63	32	88	91	160	41.5	1.790
2025 08	1 ½"	63	40	94	104	205	51.5	2.460
2025 09	2"	63	50	100	120	205	63	3.470
2025 10	2 ½"	63	65	150	155	330	83.5	8.500
2025 11	3"	63	80	165	182	330	100	12.400
2025 12	4"	63	100	175	220	340	118.5	19.650

Ref.	Medida / Size	PN	Dimensiones / <i>Dimensions</i> (mm)		
			H	C x C	ISO 5211
2025 02	1/4"	63	10	9 x 9	F-03
2025 03	3/8"	63	10	9 x 9	F-03
2025 04	1/2"	63	11	9 x 9	F-03/F-04
2025 05	3/4"	63	11	11 x 11	F-04/F-05
2025 06	1"	63	11	11 x 11	F-04/F-05
2025 07	1 ¼"	63	15	14 x 14	F-05/F-07
2025 08	1 ½"	63	15	14 x 14	F-05/F-07
2025 09	2"	63	15	14 x 14	F-05/F-07
2025 10	2 ½"	63	19	17 x 17	F-07/F-10
2025 11	3"	63	19	17 x 17	F-07/F-10
2025 12	4"	63	19	17 x 17	F-07/F-10

**CURVA PRESIÓN TEMPERATURA / PRESSURE TEMPERATURE RATING**

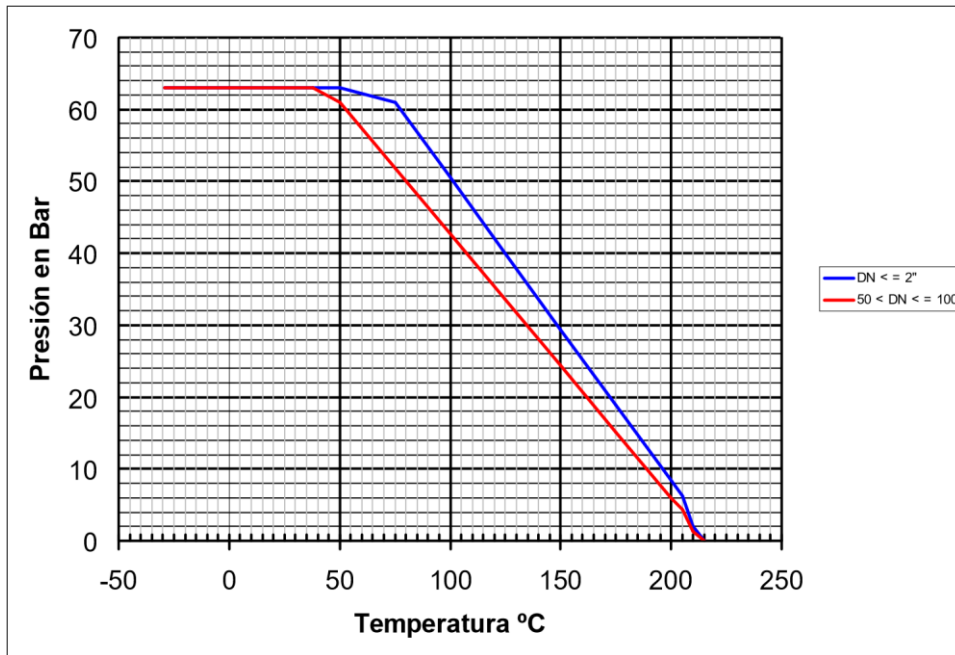

**VALORES DE Kv / Kv VALUES**

Kv = Es la cantidad de metros cúbicos por hora (m<sup>3</sup>/h) que pasará a través de la válvula generando una pérdida de carga de 1 bar.

*Kv = Flow rate of water in cubic meter per hour (m<sup>3</sup>/h) that will generate a pressure drop of 1 bar across the valve.*

1/4"	3/8"	1/2"	3/4"	1"	1 1/4"	1 1/2"	2"	2 1/2"	3"	4"
6	10	24	43	83	130	205	340	520	1100	1820

DIAGRAMA DE PERDIDA DE CARGA / HEADLOSS CHART  
VÁLVULAS PASO TOTAL ROSCADAS / THREAD ENDS FULL BORE BALL VALVES

