

Directional spool valves, direct operated, with solenoid actuation

Type WE ...XN



- ▶ Size 6
- ▶ Component series 6X
- ▶ Maximum operating pressure 350 bar
- ▶ Maximum flow 80 l/min



ATEX units For potentially explosive atmospheres



Information on explosion protection:

- ▶ Area of application in accordance with the Explosion Protection Directive 2014/34/EU: **II 3G; II 3D**
- ▶ Area of application according to technical rules EAC TR CU 012/2011: **II 3G; II 3D**
- ▶ Type of protection valve:
 - Ex h IIC T3 Gc X according to EN 80079-36
 - Ex h IIIC T140°C Dc X according to EN 80079-36
- ▶ Type of protection, solenoid coil:
 - Ex ec IIC T3 Gc according to EN 60079-7
 - Ex tc IIIC T140°C Dc according to EN 60079-31

Features

- ▶ 4/3, 4/2 or 3/2-way version
- ▶ For intended use in potentially explosive atmosphere
- ▶ Porting pattern according to ISO 4401-03-02-0-05
- ▶ Wet-pin DC solenoids
- ▶ Solenoid coil is rotatable by 90°
- ▶ Electrical connection with individual connection
- ▶ With concealed manual override

Contents

Features	1
Ordering code	2
Symbols	3
Function, section	4
Technical data	5 ... 7
Characteristic curves	8
Performance limits	8
Dimensions	9
Installation conditions	10
Electrical connection	11
Over-current fuse and switch-off voltage peaks	11
Accessories	12
Further information	12

 **Notice:** The documentation version with which the product was supplied is valid.

Ordering code

01	02	03	04	05	06	07	08	09	10	11	12	13	
	WE	6		6X	/		E	G24	N9	XN	K4	/	

01	3 main ports	3
	4 main ports	4
02	Directional valve	WE
03	Size 6	6
04	Symbols; possible versions, see page 3	
05	Component series 60 ... 69 (60 ... 69: unchanged installation and connection dimensions)	6X
06	With spring return	no code
	Without spring return	O
	Without spring return with detent	OF
07	High-power solenoid, wet (wet-pin) with detachable coil	E

Supply and mains voltage

08	Direct voltage 24 V	G24
----	---------------------	------------

Manual override

09	With concealed manual override	N9
----	---------------------------------------	-----------

Explosion protection

10	"Not igniting"	XN
	For details, see information on the explosion protection page 7	

Electrical connection

11	Individual connection	
	Solenoid without mating connector	K4
	For details of electrical connections, see page 11	

Throttle insert

12	Without throttle insert (standard)	no code
	Throttle Ø 0.8 mm	B08
	Throttle Ø 1.0 mm	B10
	Throttle Ø 1.2 mm	B12
	Use if volume flow > performance limit of the valve, effective in channel P	

Seal material (observe compatibility of seals with hydraulic fluid used, see page 6)

13	NBR seals	no code
	FKM seals	V

Symbols

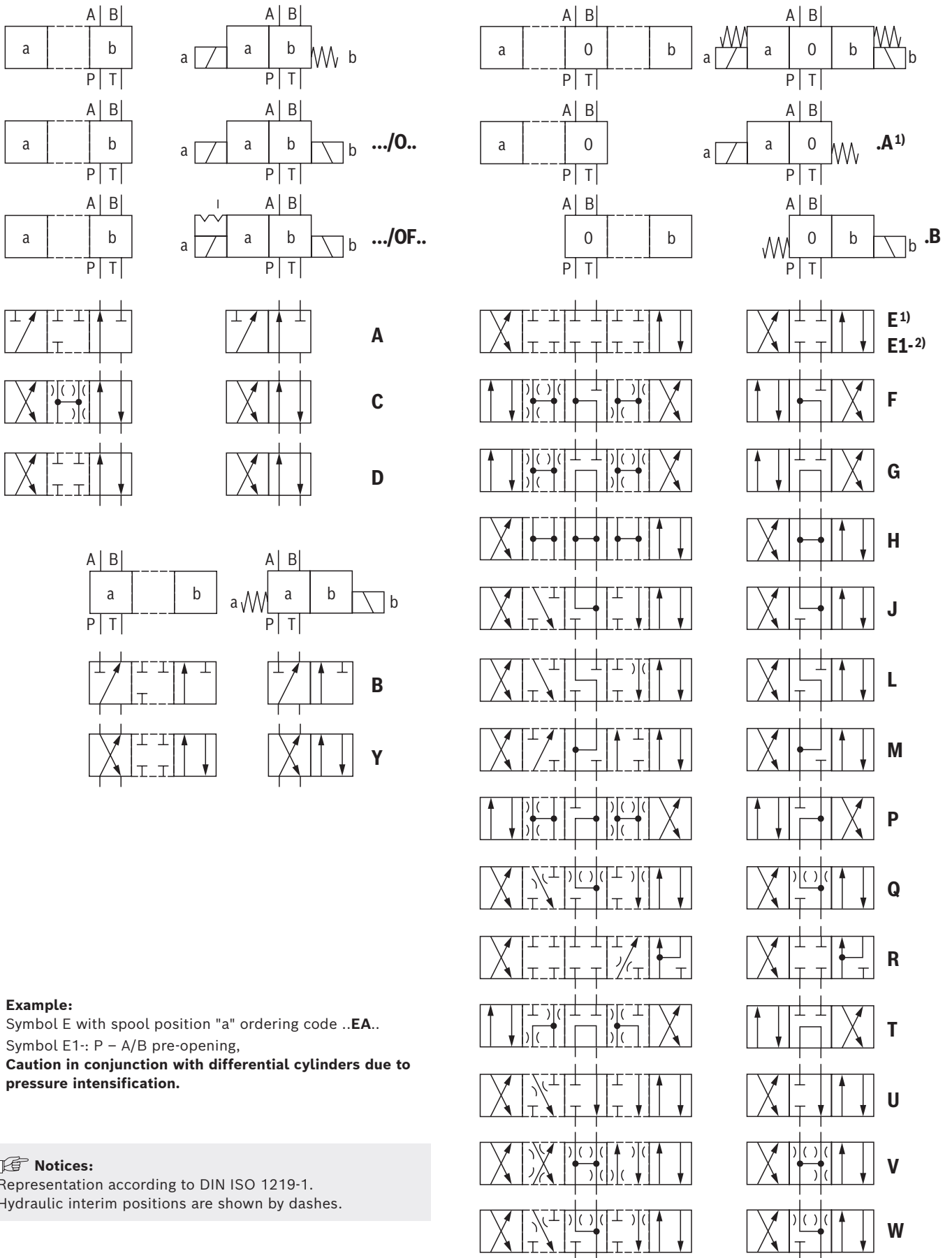

- 1) **Example:**
Symbol E with spool position "a" ordering code ..EA..
- 2) Symbol E1-: P – A/B pre-opening,
Caution in conjunction with differential cylinders due to pressure intensification.

Notices:
Representation according to DIN ISO 1219-1.
Hydraulic interim positions are shown by dashes.

Function, section

Directional valves of type WE are solenoid-actuated directional spool valves. They control start, stop and direction of a flow.

The directional valves basically consist of housing (1), one or two electronic solenoids (2), control spool (3), and one or two return springs (4).

In the de-energized condition, control spool (3) is held in the central position or in the initial position by the return springs (4) (except for impulse spools). The control spool (3) is actuated by wet-pin electronic solenoids (2).

For unobjectionable functioning, the hydraulic system has to be bled properly.

The force of the electronic solenoid (2) acts via the plunger (5) on the control spool (3) and pushes the latter from its rest position to the required end position.

This enables the necessary direction of flow from P to A and B to T or P to B and A to T.

After electronic solenoid (2) was de-excited, the return spring (4) pushes the control spool (3) back to its rest position.

A manual override (6) allows control spool (3) to be moved without solenoid energization.

Without spring return "O" (only possible with symbols A, C and D)

This version is a directional valve with two spool positions and two electronic solenoids **without** detent. The valve without spring return at the control spool (3) does not have a defined basic position in de-energized condition.

Without spring return, with detent "OF" (only possible with symbols A, C and D)

This version is a directional valve with two spool positions and two electronic solenoids **with** detent. Due to the detent, the control spool (3) is fixed in its respective spool position. For energy-efficient operation, continuous application of current at the electronic solenoid is not required.

Notices:

Pressure peaks in the tank line to two or several valves can result in unintended movements of the control spool in case of valves with detent. We therefore recommend that separate return lines be provided or a check valve installed in the tank line.

The tank line must not be allowed to run empty.

With corresponding installation conditions, a preload valve (preload pressure approx. 2 bar) must be installed.

Due to the design principle, internal leakage is inherent to the valves, which may increase over the life cycle.

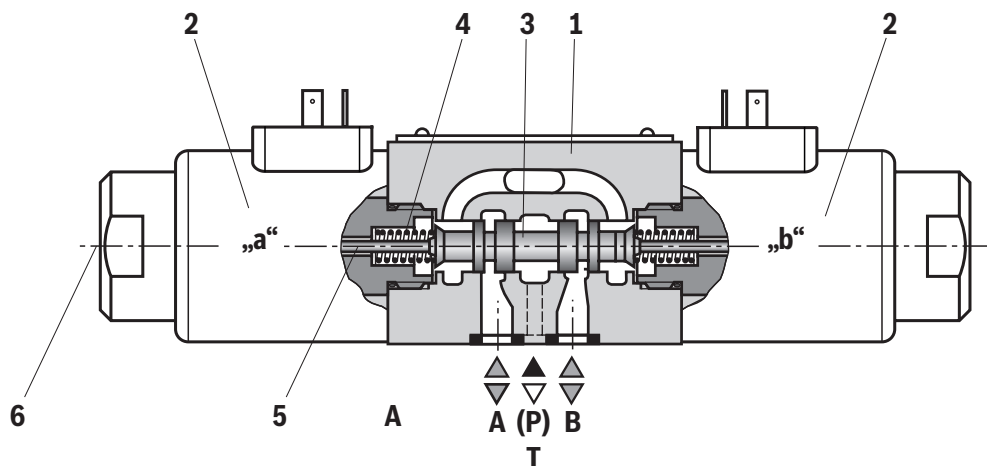

Type 4WE 6 E6X/...E..XNK4...

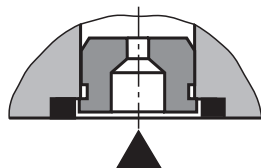

Throttle insert

The use of a throttle insert is required when, due to prevailing operating conditions, flows occur during the switching processes, which exceed the performance limit of the valve.

Technical data

(for applications outside these values, please consult us!)

General			
Installation position			any
Ambient temperature range	°C		-20 ... +50 ¹⁾
Storage temperature range	°C		+5 ... +40
Maximum storage time	Years		1
Maximum admissible acceleration a_{max}	g		10
Weight	▶ Valve with one solenoid	kg	2.3
	▶ Valve with two solenoids	kg	2.85
Surface protection			galvanic coating
Hydraulic			
Maximum operating pressure	▶ Port P, A, B	bar	350
	▶ Port T	bar	210 With symbols A and B, port T must be used as leakage oil connection if the operating pressure exceeds the admissible tank pressure.
Maximum flow		l/min	80
Flow cross-section (spool position 0)	▶ Symbol Q	mm ²	approx. 6% of nominal cross-section
	▶ Symbol W	mm ²	approx. 3% of nominal cross-section
Hydraulic fluid			See table page 6
Hydraulic fluid temperature range (at the working ports of the valve)		°C	-20 ... +80 (NBR seals) ²⁾
			-15 ... +80 (FKM seals) ²⁾
Viscosity range		mm ² /s	2.8 ... 500
Maximum admissible degree of contamination of the hydraulic fluid Cleanliness class according to ISO 4406 (c)			Class 20/18/15 ³⁾

¹⁾ Maximum 40 °C when using the cable sets DS2513, see page 12

²⁾ Please observe the "Special application conditions for safe application" on page 7.

³⁾ The cleanliness classes specified for the components must be adhered to in hydraulic systems. Effective filtration prevents faults and simultaneously increases the life cycle of the components.

Available filters can be found at www.boschrexroth.com/filter.

Technical data

(for applications outside these values, please consult us!)

Hydraulic fluid	Classification	Suitable sealing materials	Standards	Data sheet
Mineral oils	HL, HLP, HLPD	NBR, FKM	DIN 51524	90220
Bio-degradable	▶ Insoluble in water	HETG	ISO 15380	90221
		HEES		
	▶ Soluble in water	HEPG	ISO 15380	
Flame-resistant	▶ Containing water	HFC (Fuchs: Hydrotherm 46M, Renosafe 500; Petrofer: Ultra Safe 620; Houghton: Safe 620; Union: Carbide HP5046)	ISO 12922	90223

**Important information on hydraulic fluids:**

- ▶ For further information and data on the use of other hydraulic fluids, please refer to the data sheets above or contact us.
- ▶ There may be limitations regarding the technical valve data (temperature, pressure range, life cycle, maintenance intervals, etc.).
- ▶ The ignition temperature of the hydraulic fluid used must be 50 K higher than the maximum surface temperature.
- ▶ **Bio-degradable and flame-resistant – containing water:** If components with galvanic zinc coating (e.g. version "J3" or "J5") or parts containing zinc are used, small amounts of dissolved zinc may get into the hydraulic system and cause accelerated aging of the hydraulic fluid. Zinc soap may form as a chemical reaction product, which may clog filters, nozzles and solenoid valves – particularly in connection with local heat input.

▶ Flame-resistant – containing water:

- Due to increased cavitation tendency with HFC hydraulic fluids, the life cycle of the component may be reduced by up to 30% as compared to the use with mineral oil HLP. In order to reduce the cavitation effect, it is recommended – if possible specific to the installation – to back up the return flow pressure in ports T to approx. 20% of the pressure differential at the component.
- Dependent on the hydraulic fluid used, the maximum ambient and hydraulic fluid temperature must not exceed 50 °C. In order to reduce the heat input into the component, a maximum duty cycle of 50% in continuous operation has to be set for on/off valves (measuring period 300 s). If this is not possible due to the function, an energy-reducing control of these components is recommended, e.g. via a PWM plug-in amplifier.

Electric			
Voltage type		Direct voltage (DC)	
Nominal voltage	V	24	
Voltage tolerance	%	± 10	
Admissible residual ripple	%	< 5	
Duty cycle / operating mode according to VDE 0580		100% / S1 (continuous operation)	
Rated current	mA	950	
Switching times according to ISO 6403 ⁴⁾	▶ ON	ms	25 ... 45
	▶ OFF	ms	10 ... 25
Maximum switching frequency	1/h	15000	
Maximum switch-off voltage peaks Solenoid	V	500, suitable damping by user required	
Nominal power at ambient temperature 20 °C	W	23	
Maximum power with 1.1 x nominal voltage and ambient temperature 20 °C	W	28.8	
Protection class according to EN 60529		IP65 (With correctly installed electrical connection)	

⁴⁾ The switching times were determined at a hydraulic fluid temperature of 40 °C and a viscosity of 46 cSt. Deviating hydraulic fluid temperatures can result in different switching times. Switching times change dependent on operating time and application conditions.

Technical data

(for applications outside these values, please consult us!)

Information on explosion protection – Directive 2014/34/EU		
Area of application	II 3G	II 3D
Type of protection of valve according to EN 80079-36 ⁵⁾	Ex h IIC T3 Gc X	Ex h IIIC T140°C Dc X
Type of protection valve solenoid according to EN 60079-7 / EN 60079-31	Ex ec IIC T3 Gc	Ex tc IIIC T140°C Dc
Maximum surface temperature ^{6; 7)}	°C 140	
Temperature class	T3	–
Type examination certificate solenoid	BVS 12 ATEX E 062 X	
Information on explosion protection – Technical rules EAC TR CU 012/2011		
Area of application	II 3G	II 3D
Type of protection marking of valve	2Ex nA II T3 Gc X	Ex tc IIIC T140°C Dc X
Maximum surface temperature ^{6; 7)}	°C 140	
Temperature class	T3	–
Certificate of conformity	№ TC RU C-DE.ГБ08.B.02161	

5) Ex h: structural safety c according to EN 80079-37.

6) Surface temperature > 50 °C, provide contact protection.

7) The transfer temperature from the connector of the valve solenoid to the mating connector is 100 °C at an ambient temperature of 50 °C.

Special application conditions for safe application:

- ▶ Connection lines must be passed in a strain-relieved way. The first mounting point must be within 150 mm of the mating connector.
- ▶ The valve is to be installed so that no impact stresses > 4 J can take effect.
- ▶ In order to avoid dangers caused by static charge, the base and/or subplate on which the valve is to be fitted must be electrically conductive and included in the equipotential bonding.
- ▶ The valve solenoid must not be installed close to charge generating processes.
- ▶ Maximum admissible dust layer thickness 5 mm.
- ▶ Maximum hydraulic fluid temperature:
In case of bank assembly, as long as only one solenoid is energized at a time, and in case of individual assembly +80 °C
In case of bank assembly when more than one solenoid is energized at a time +65 °C
- ▶ The maximum temperature of the surface of the valve jacket is 110 °C. This has to be considered when selecting the connection cable and/or contact of the connection cable with the surface of the jacket is to be prevented.

Characteristic curves

(measured with HLP46, $\vartheta_{oil} = 40 \pm 5 \text{ }^\circ\text{C}$)

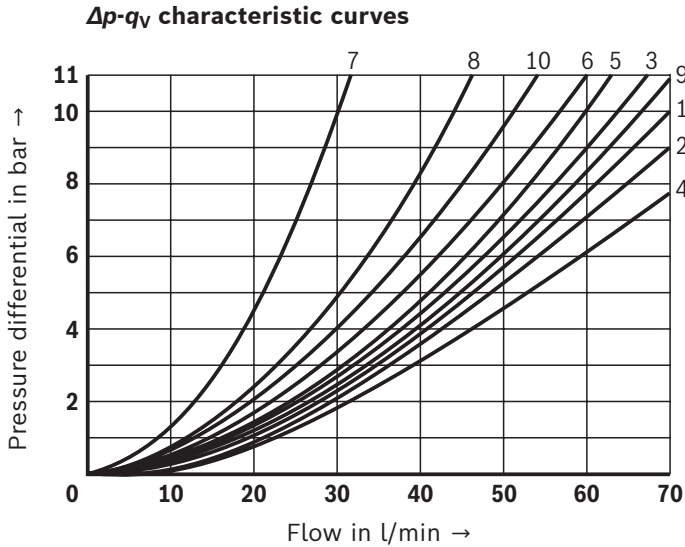

Symbol	Direction of flow					
	P - A	P - B	A - T	B - T	B - A	P - T
A, B	3	3	-	-	-	-
C	1	1	3	1	-	-
D, Y	5	5	3	3	-	-
E	3	3	1	1	-	-
F	1	3	1	1	-	-
T	10	10	9	9	-	8
H	2	4	2	2	-	9
J, Q	1	1	2	1	-	-
L	3	3	4	9	-	-
M	2	4	3	3	-	-
P	3	1	1	1	-	-
R	5	5	4	-	7	-
V	1	2	1	1	-	-
W	1	1	2	2	-	-
U	3	3	9	4	-	-
G	6	6	9	9	-	8

Performance limits

(measured with HLP46, $\vartheta_{oil} = 40 \pm 5 \text{ }^\circ\text{C}$)

Notice:

The specified performance limits are valid for operation with two directions of flow (e.g. from P to A and simultaneous return flow from B to T). Due to the flow forces acting within the valves, the possible performance limit may be considerably lower

with only one direction of flow (e.g. from P to A while port B is blocked)!
The performance limits were determined when the solenoids were at operating temperature, at 10% undervoltage and without tank preloading.

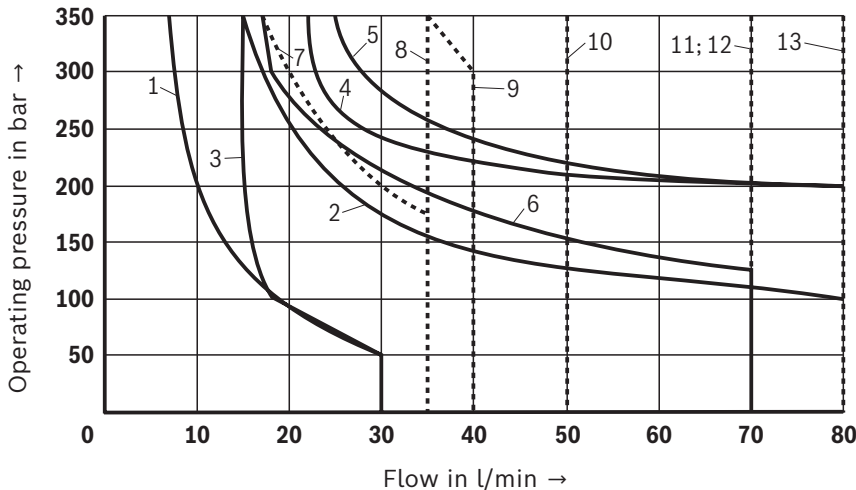

Symbol	Characteristic curve
A,B	1
J,L,U	2
V	3
D,C,Y	4
Q,W	5
A/O, A/OF	6
F,P	7
T	8
G	9
H	10
D/OF, C/OF	11
M, D/O, C/O	12
E1, R, E	13

Dimensions

(dimensions in mm)

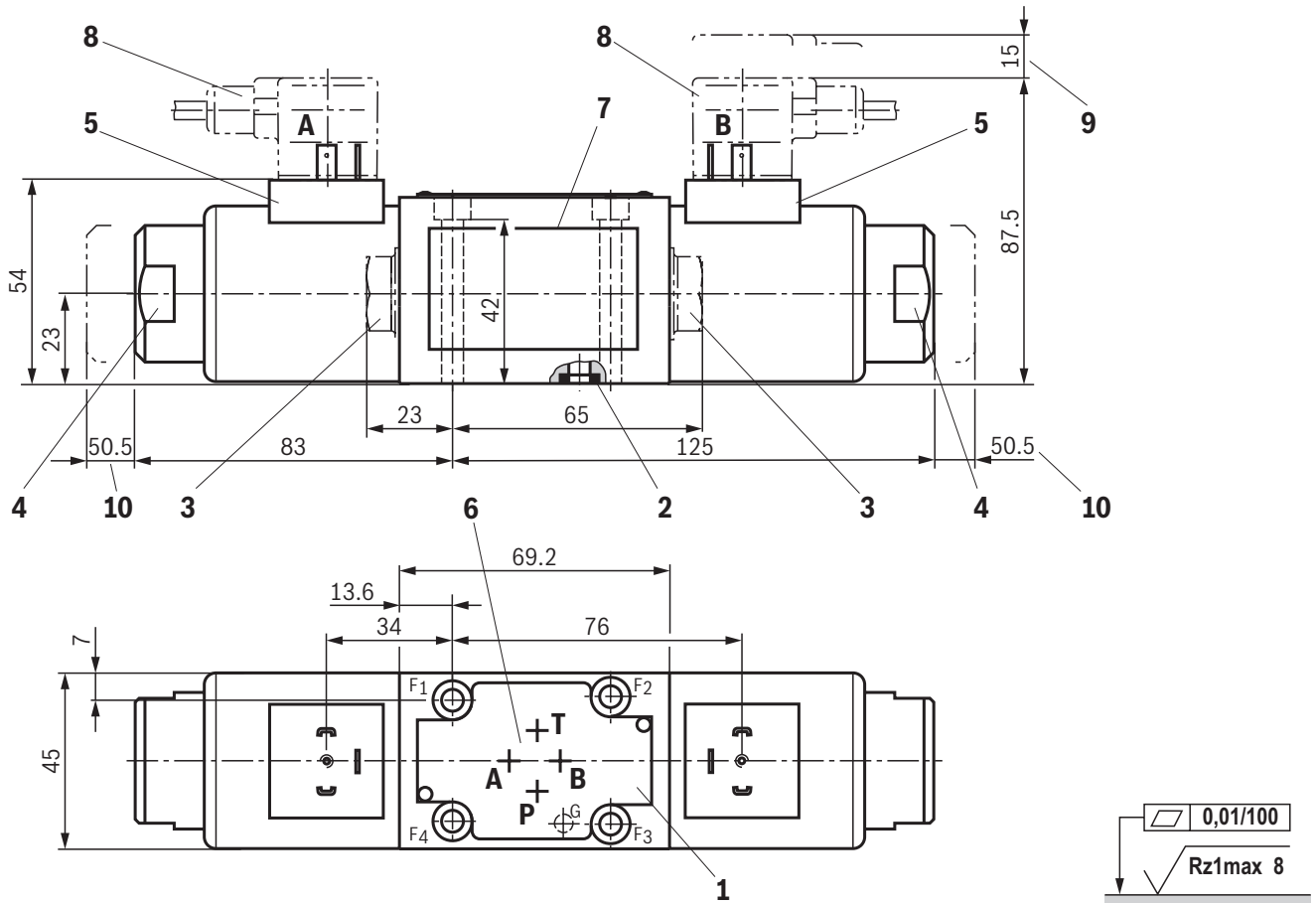

Required surface quality of the valve contact surface

- 1 Name plate of valve
- 2 Identical seal rings for ports A, B, P, T
- 3 Plug screw for valves with one solenoid
- 4 Mounting nut with double edge, wrench size 32
- 5 Plug-in connector according to EN 175301-803, design A (cable sets, separate order, see page 12 and data sheet 08006.
- 6 Porting pattern according to ISO 4401-03-02-0-05
- 7 Name plate sticker
- 8 Cable set DS2513 **without** circuitry for connector "K4" (separate order, see page 12 and data sheet 08006)
- 9 Space required to remove the cable set
- 10 Space required to remove the coil

Valve mounting screws (separate order)

Only use valve mounting screws with the subsequently listed thread diameters and strength properties. Observe the screw-in depth.

4 hexagon socket head cap screws

ISO 4762 - M5 x 50 - 10.9

(friction coefficient $\mu_{\text{total}} = 0.09 \dots 0.14$);

Material no. **R913043758**

Subplates (separate order) with porting pattern according to ISO 4401-03-02-0-05, see data sheet 45100.

Notices:

- ▶ Subplates are no components in the sense of Directive 2014/34/EU and can be used after the manufacturer of the overall system has conducted an assessment of the risk of ignition. The "G...J3" versions are free from aluminum and/or free from magnesium and galvanized.
- ▶ The dimensions are nominal dimensions which are subject to tolerances.

Installation conditions (dimensions in mm)

	Individual assembly	Bank assembly
Subplate dimensions	Minimum dimensions length ≥ 64 , width ≥ 58 , height ≥ 25	Minimum cross-section height ≥ 60 , width ≥ 85
Thermal conductivity of the subplate	≥ 36.2 W/mK	
Minimum distance between the longitudinal valve axes	≥ 55	

Individual assembly

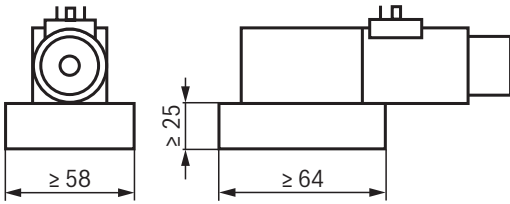

Bank assembly

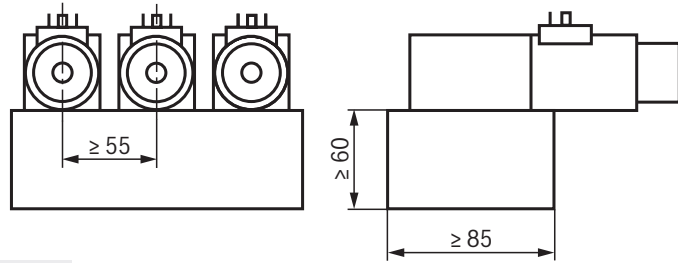

 **Notice:**

With regard to the hydraulic fluid temperature, observe the "Special conditions for safe use" on page 7.

Electrical connection

The type-examination tested solenoid coil of the valve is equipped with an electrical connection according to the following table. The electrical connection of the solenoid is polarity-independent.

Electrical connections and coil connection combinations

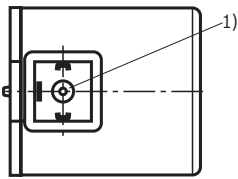
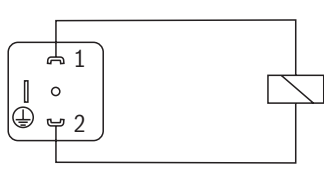
Connector ordering code	Top view	Circuit diagram	Pin	Connections, assignment
Connector, 3-pole (2+PE) according to DIN EN 175301-803 (IP65)			1 2 ⊕	Solenoid coil, polarity-independent Grounding

¹⁾ M3, maximum tightening torque $M_{A \max} = 1 \text{ Nm}$

Requirements for cable sets and mating connectors not listed under "Accessories"		
Temperature rating (cables, connectors, seals)	°C	≤-30 ... ≥+100
Minimum wire cross-section	mm ²	0.75
Protection class according to EN 60529		IP65

Notice:

All three contacts of the solenoid coil (1, 2 and grounding) must be properly connected (3-wire line)

Over-current fuse and switch-off voltage peaks

Voltage data in the valve type code	Nominal voltage Valve solenoid	Rated current Valve solenoid	Recommended pre-fuse characteristics medium time-lag according to DIN EN 60127-1
G24	24 V DC	0.95 A DC	1 A

Notice:

A fuse which corresponds to the rated current according to DIN 41571 and EN / IEC 60127 has to be connected upstream of every valve solenoid (max. $3 \times I_{\text{rated}}$).

The shut-off threshold of the fuse has to match the prospective short-circuit current of the supply source.

The prospective short-circuit current of the supply source may

amount to a maximum of 1500 A.

This fuse may only be installed outside the potentially explosive atmospheres or must be of an explosion-proof design.

When inductivities are switched off, voltage peaks result which may cause faults in the connected control electronics.

The voltage peak must be damped by a suitable external circuitry.

We recommend a circuitry with a suppressor diode with a limitation voltage of approx. 50 V.

Accessories (separate order)**Cable sets**

Item 1)	Designation	Version	Short designation	Material number	Data sheet
5, 8	Cable sets; for ATEX valves with "K4" connector, 2-pole + PE, design A (large cubic connector) 2)	3.0 m	DS2513...ATEX	R901200418	08006
		5.0 m		R901200460	
		12.0 m		R901200582	

1) See dimensions on page 9.

2) Maximum ambient temperature range 40 °C.
Only with individual control of the solenoid. Not admissible
for bank assembly with simultaneous power supply of several
solenoids.

Further information

- ▶ Subplates Data sheet 45100
- ▶ Use of non-electrical hydraulic components in an explosive environment (ATEX) Data sheet 07011
- ▶ Hydraulic fluids on mineral oil basis Data sheet 90220
- ▶ Environmentally compatible hydraulic fluids Data sheet 90221
- ▶ Flame-resistant hydraulic fluids - containing water (HFAE, HFAS, HFB, HFC) Data sheet 90223
- ▶ Directional spool valves, direct operated, with solenoid actuation Operating instructions 23178-XN-B
- ▶ Selection of filters www.boschrexroth.com/filter
- ▶ Information on available spare parts www.boschrexroth.com/spc

Bosch Rexroth AG
Industrial Hydraulics
Zum Eisengießer 1
97816 Lohr am Main, Germany
Phone +49 (0) 93 52/40 30 20
my.support@boschrexroth.de
www.boschrexroth.de

© All rights reserved to Bosch Rexroth AG, also regarding any disposal, exploitation, reproduction, editing, distribution, as well as in the event of applications for industrial property rights.
The data specified above only serve to describe the product. No statements concerning a certain condition or suitability for a certain application can be derived from our information. The information given does not release the user from the obligation of own judgment and verification.
It must be remembered that our products are subject to a natural process of wear and aging.